

AN01: GaAs MMIC handling and die attach recommendations

Summary

- GaAs MMICs are sensitive to ESD damage; take ESD precautions!
- Do not contact the die surface, handle from the edges to avoid airbridges
- Centellax recommends epoxy die attach with Ablestick 84-1LMI adhesive
 - Epoxy die attach requires a thin layer of epoxy; less than 0.75mil thick
 - Solder die attach (<300C for <1 minute) may be used for some applications
- Centellax recommends 0.7mil gold bondwire (multiple bonds for RF in/out)
- See high-performance recommendations on last page for best use

Handling MMICs

Electrostatic Discharge (ESD)

GaAs MMICs may be destroyed or damaged by electrostatic discharge; ESD damage is often not obvious at the time of exposure. Proper ESD precautions must be employed when handling GaAs MMICs.

Grounding is critical for floors and all work surfaces, bonding and handling equipment, and other test or assembly machinery. Operators should always wear wrist or foot ground straps. ESD test equipment should be available to insure proper ESD grounding at all times.

Handle Die from Edges

During GaAs MMIC assembly, handle the die along the edge; do not contact the surface of the die. Use tweezers or a vacuum collet sized to contact the edges of the die, so that plated airbridges are not damaged or deformed during handling and assembly.

MMIC Die Attach

Two methods are commonly used to attach GaAs MMICs to microcircuit packages or pedestals: solder and epoxy. Solder (usually eutectic) has historically been the only method of MMIC die attach. In recent years, there have been significant advances in epoxy technology for this application. As a result, epoxy die attach has become the preferred die attach method in most MMIC applications.

Centellax recommends epoxy die attach with Ablestick 84-1LMI adhesive for most applications. For more information, contact support@centellax.com.

AN01: GaAs MMIC handling and die attach recommendations

Epoxy Die Attach

Advantages of epoxy die attach include production efficiency, reduced rework, increased placement accuracy, and less sensitivity to thermal expansion mismatch of the GaAs MMIC to its mounting substrate.

The perceived disadvantage of epoxy is their relatively high thermal resistance compared to solder. This is largely a misconception when considering the very thin layer of epoxy required, which results in a smaller temperature gradient through the die attach layer.

Die attach epoxies are available as a pre-form or in a mixing dispenser. The major consideration when using epoxies is the final die attach layer thickness. This layer needs to be considerably less than one mil thick. The accepted target is one-fourth to three-fourths of a mil thick. The thin layer maintains a low thermal gradient through the epoxy and a low inductance between the MMIC backside and ground. Thick layers of epoxy can present enough inductance to the RF ground circuit to introduce oscillation or other performance issues.

Too much or too little epoxy can cause problems: the epoxy fillet around the die should be approximately half-way up the side of the 4-mil thick MMIC. Too little epoxy may lead to voids (discussed in the solder section), too much epoxy may lead to stringers and shorts to the front-side metal.

There are a number of companies supplying die attach epoxies. Ablestick Corporation manufactures a variety of die attach and microcircuit adhesives. Centellax, and many others in our industry, recommend and use Ablestick 84-1LMI adhesive. For more information, contact support@centellax.com.

Solder Die Attach

Although solder die attach is being replaced in many applications by modern die attach epoxies, there are applications where solder die attach may be preferred. For example, high power dissipation MMICs require optimum thermal dissipation and may benefit from solder die attach. The high operating temperatures of these devices can sometimes soften epoxies, resulting in performance and reliability issues.

Gold-Tin (80/20) eutectic solder is the most common alloy used for MMIC solder die attach. Pre-forms are often used; they are originally smaller than the MMIC, but result in complete coverage of the backside when attached. The pre-form size is determined experimentally. Various methods are used to apply pressure and a scrubbing motion to the MMIC to embed the die into the solder.

AN01: GaAs MMIC handling and die attach recommendations

Solder die attach results in a more rigid connection to the mounting surface compared with epoxy. Selection of the die attach material should consider the differences in thermal expansion coefficients (CTE) between the die and the mounting surface. MMICs will crack if there are large differences in expansion between the materials. Often MMICs are mounted on pedestals which are made of kovar, molybdenum, or silicon, because these materials closely match the expansion of GaAs (~7ppm/C), and are good thermal conductors.

Another important consideration when using solder die attach is the possibility of solder voids. A void, or air bubble, can reduce device reliability by critically reducing the thermal conductivity. If voids are located directly under FET fingers, heat will not be efficiently dissipated, and channel temperatures will increase until the device prematurely fails. Correctly sized pre-forms can reduce voids, and appropriate lengths of wire may work better and cost less.

If solder die attach is required, Centellax recommends 80/20 Gold-Tin (Au-Sn) pre-forms. Die must not be exposed to temperatures >300C for more than 1 minute. For more information, contact support@centellax.com.

Wire Bonding

Thermosonic wire bonding is the recommended method of attaching wires to MMIC bond pads. Two thermosonic bonding tools are commonly used: wedge and capillary. For optimal bonds, the combination of bonding force, time, and temperature is critical. Manufacturers of wire bonding equipment provide technical information, a good starting point for successful wire bonding to MMIC bond pads. Centellax can provide scrap die for bonding practice.

Ensure the bonding tool is grounded. Be very careful to not touch the surface of the MMIC during the bonding procedure (bond pads excluded, of course). Bond first to the die, then to the package. Use multiple short bondwires for RF input and output pads. Take care to observe the recommended assembly diagrams provided for each Centellax MMIC, and be sure to bond to the appropriate pads.

Centellax typically recommends 0.7-mil soft gold bondwire, used with a rear-feed wedge bond tool with a 1mil bonding face. For more information, contact support@centellax.com.

AN01: GaAs MMIC handling and die attach recommendations

MMIC Performance

MMIC performance can often be affected by die attach and MMIC interface methods. Figure 1 illustrates Centellax high-performance recommendations.

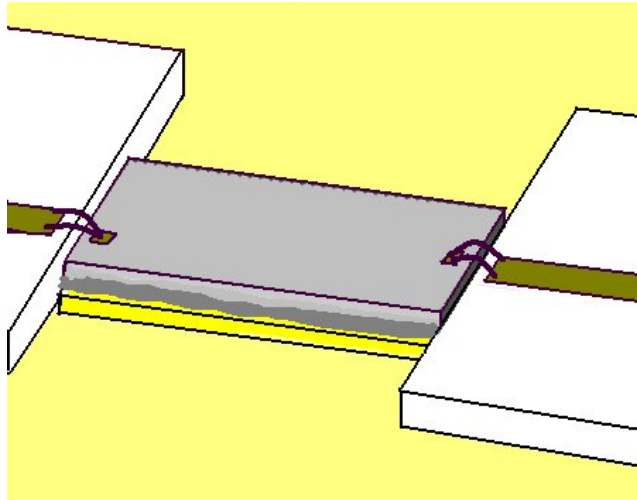

Figure 1 – Epoxy die attach to pedestal; multiple short wirebonds

Centellax recommendations for MMIC high performance:

- Use a pedestal under the die to bring the face of the die level with the RF input and output transmission line (to shorten wirebonds)
- Use multiple short wirebonds on the RF input and output pads for a low inductance connection to the MMIC
- Design the 50Ω transmission line to have a width less than 3x the bond pad width (to shorten wirebonds, but bond to the edges of the line as shown)
- Use the appropriate thickness epoxy (0.25-0.75mil, 6.4-19um) under the die

Information on Centellax MMICs is available from the Centellax website at:

<http://www.centellax.com/products/microwave/>

Please contact Centellax application engineers at support@centellax.com for additional information, or sales and marketing at sales@centellax.com for price and delivery information.