

56 Gb/s 1:4 Demultiplexer Module

Features

- Half rate clock
- High Input Sensitivity
- Wide Operating Range, 2.6-56 Gb/s
- Low Output Jitter
- Low Power Consumption
- Fast Output Rise/Fall Times



Description

The MD1S4V2M is a 1:4 demultiplexer. The module accepts input data rates from 2.6 to 56 Gb/s with an input sensitivity greater than 300mV. Differential data inputs are DC coupled and terminated with 50 ohm resistors to minimize reflections. The single-ended, half rate clock input is AC coupled and operates with low input power. The module features single-ended AC coupled outputs with ECL compatible signal levels. Data outputs and the clock input are accessed via high quality 2.9mm (K) connectors while the high speed inputs are connected via 1.85mm (V) connectors.

Operating Conditions

Parameter	Minimum	Typical	Maximum	Units
Vee	-3.7	-3.6	-3.5	V

Applications

The MD1S4V2M can be used in SONET/SDH and 100GE applications operating at transmission speeds within the demultiplexer's 2.6-56Gb/s input rate. Broadband test systems will benefit from the low power dissipation, precision connectors, and excellent output waveform characteristics. The compact size of the module allows the MD1S4V2M to be placed at the measurement plane, reducing or eliminating artifacts related to long cables.

Key Specifications @ 25°C

Vee = -3.6V, Iee = 290mA, Zo = 50Ω

Parameter	Minimum	Typical	Maximum	Minimum	Typical	Maximum	Units
Data Input							
Bit Rate	2.6	-	44	44	-	56	Gb/s
Amplitude (Single-Ended)	150	-	1000	300	-	1000	mVpp
Clock Input							
Frequency	1.3	-	22	22	-	28	GHz
Amplitude	200	-	1400	300	-	1400	mVpp
Power	-10	-	+7	-6	-	+7	dBm
Data Output							
Bit Rate	0.65	-	11	11	-	14	Gb/s
Amplitude	210	240	270	200	225	250	mVpp
Jitter RMS	-	0.8	1.2	-	1.6	2	psec
Jitter Pk-Pk	-	6	8	-	10	12	psec
Rise Time	-	8	10	-	8	10	psec
Fall Time	-	8	10	-	8	10	psec
SNR	10	-	-	10	-	-	dB

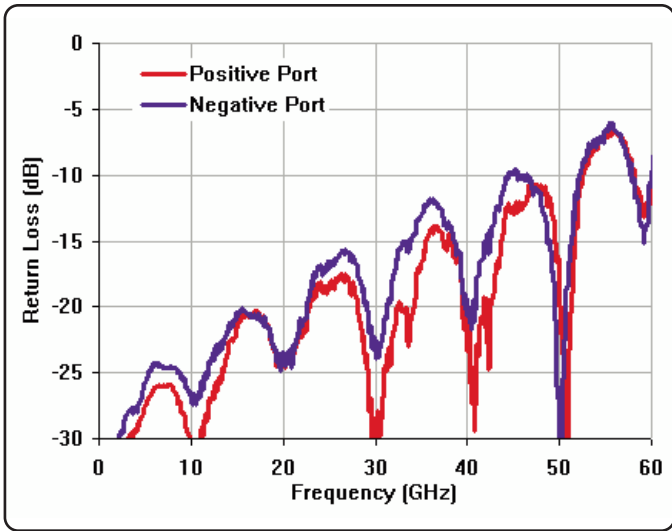

Figure 1: Data Input Return Loss

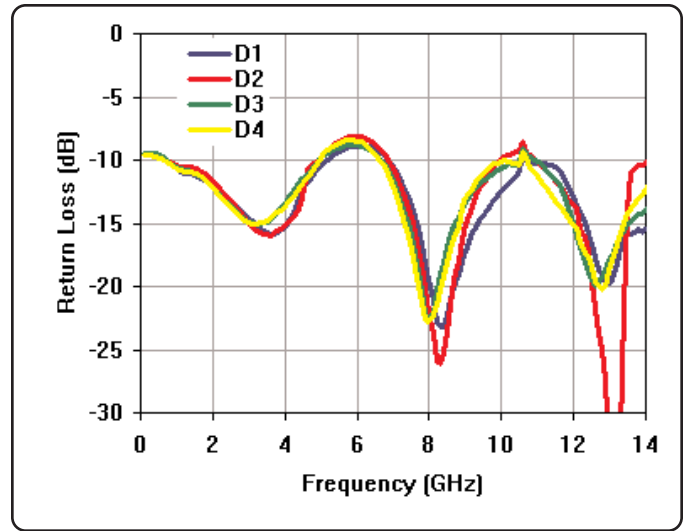

Figure 2: Data Output Return loss

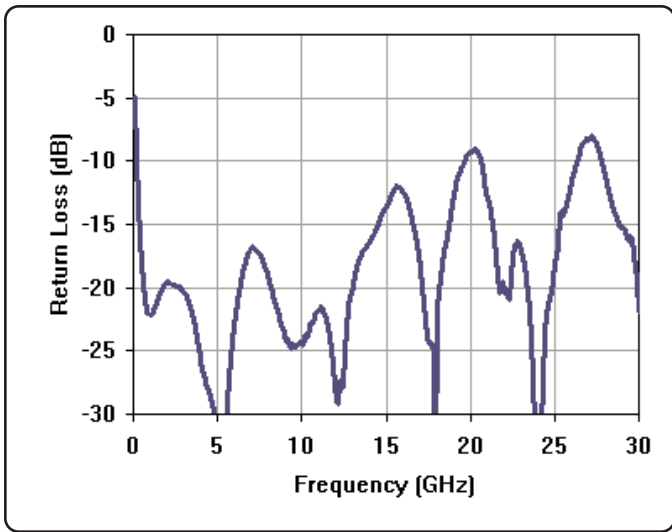

Figure 3: Clock Input Return Loss

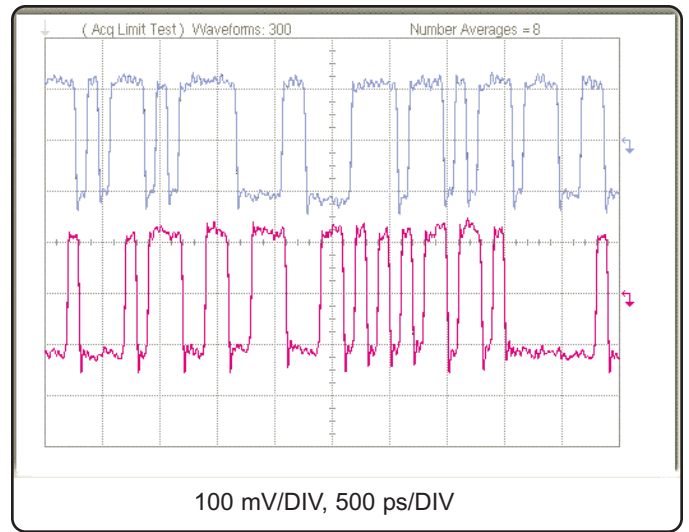

Figure 4: Data Output Waveforms @ 10Gb/s
Top: D3, Bottom: D4

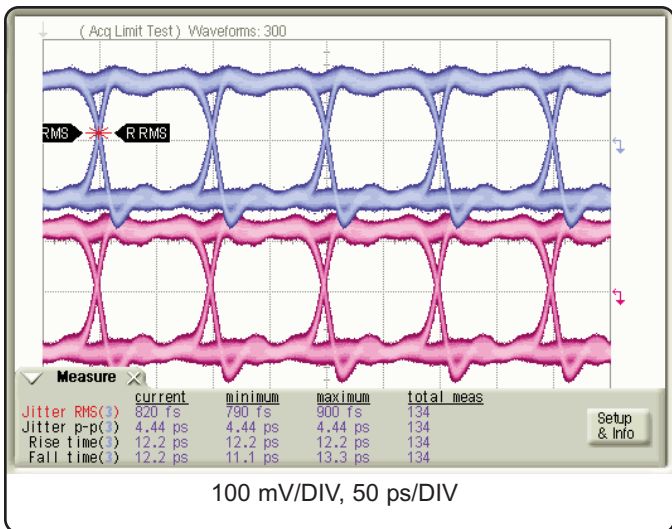

Figure 5: Data Output Eye Diagrams @ 10Gb/s
Top: D1, Bottom: D2

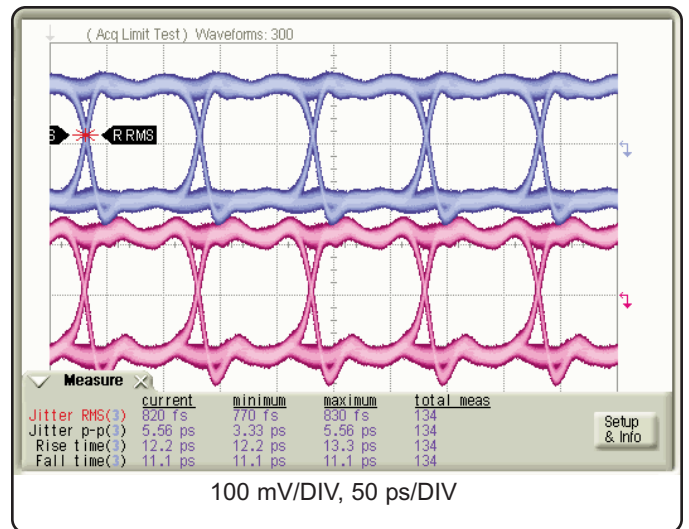

Figure 6: Data Output Eye Diagrams @ 10Gb/s
Top: D3, Bottom: D4

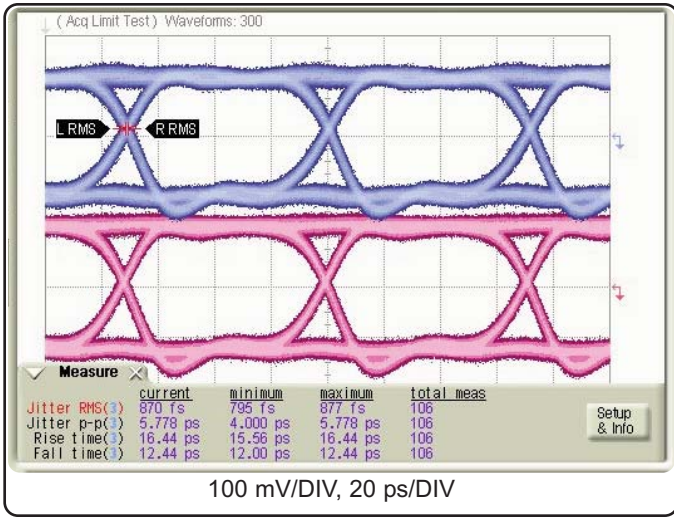

Figure 7: Data Output Eye Diagrams @ 14Gb/s
Top: D1, Bottom: D2

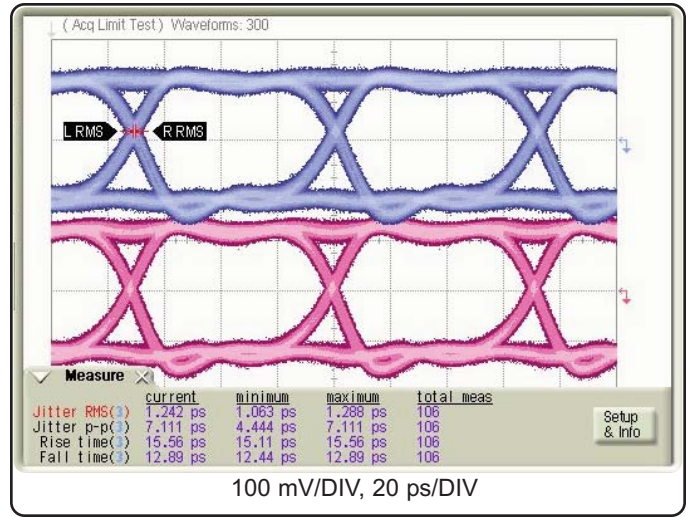

Figure 8: Data Output Eye Diagrams @ 14Gb/s
Top: D3, Bottom: D4

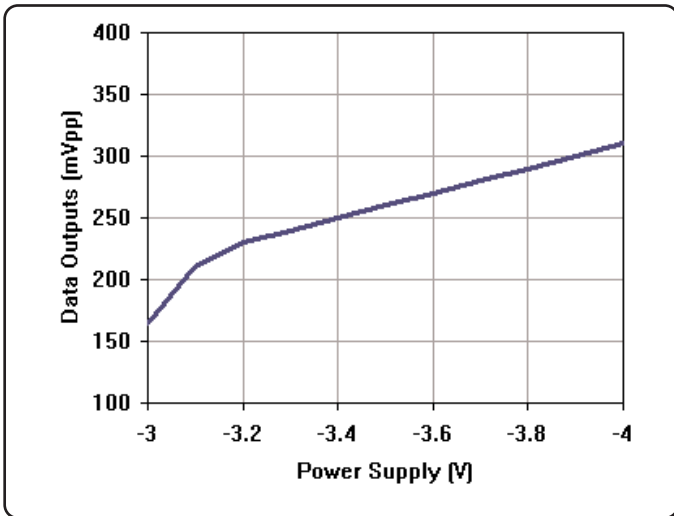

Figure 9: Data Output Amplitude vs Power Supply
Output Data Rate @ 10Gb/s

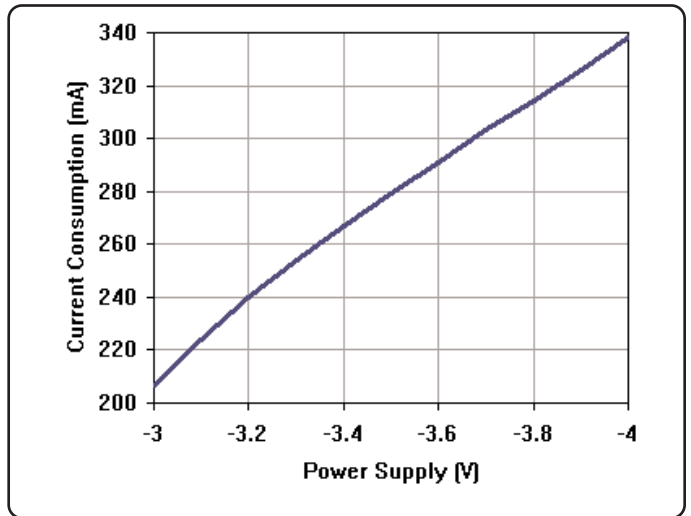

Figure 10: Total Current Consumption vs Power Supply Level

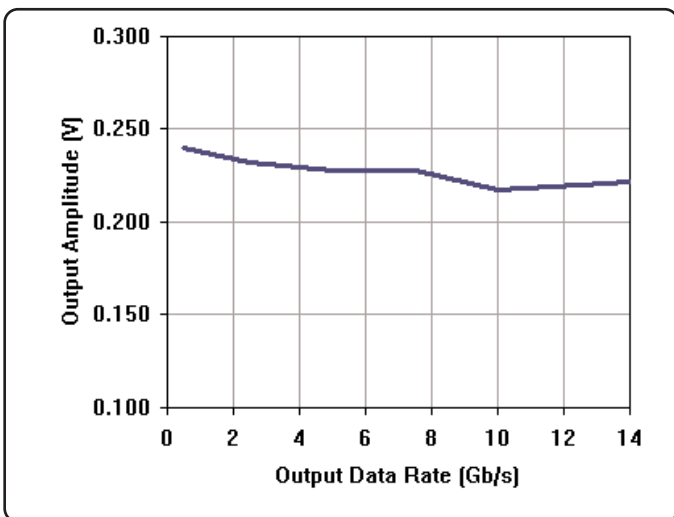

Figure 11: Data Output Amplitude vs Data Rate
Power Supply @ -3.6V

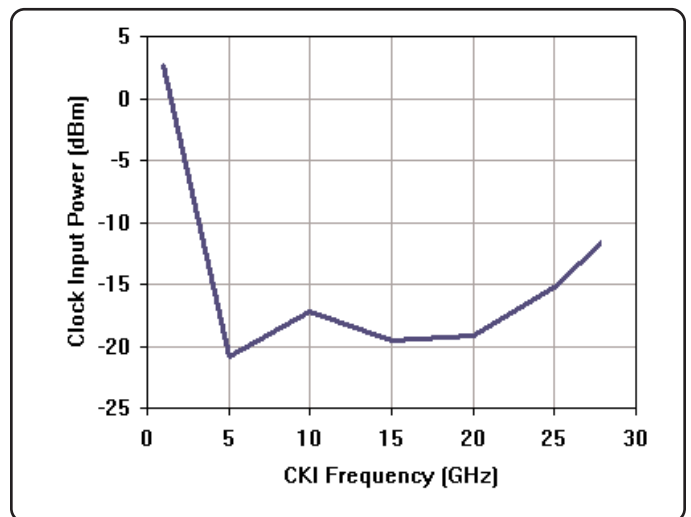
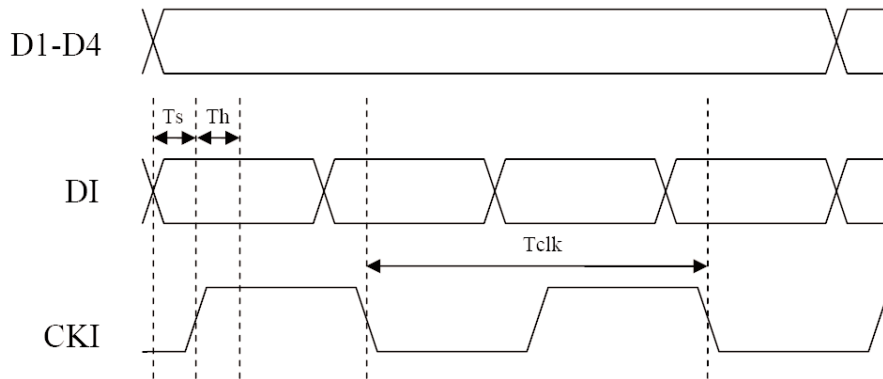

Figure 12: Clock Input Sensitivity vs Frequency
Power Supply @ -3.6V

Timing Diagram



Parameter	Description	Minimum	Typical	Maximum
T _s (ps)	Setup Time	4	-	-
T _h (ps)	Hold Time	4	-	-
DI (Gb/s)	Input Data	2	-	56
D1-D4 (Gb/s)	Output Data	0.5	-	14
CKI (GHz)	Input Clock	1	-	28

Functional Block Diagram

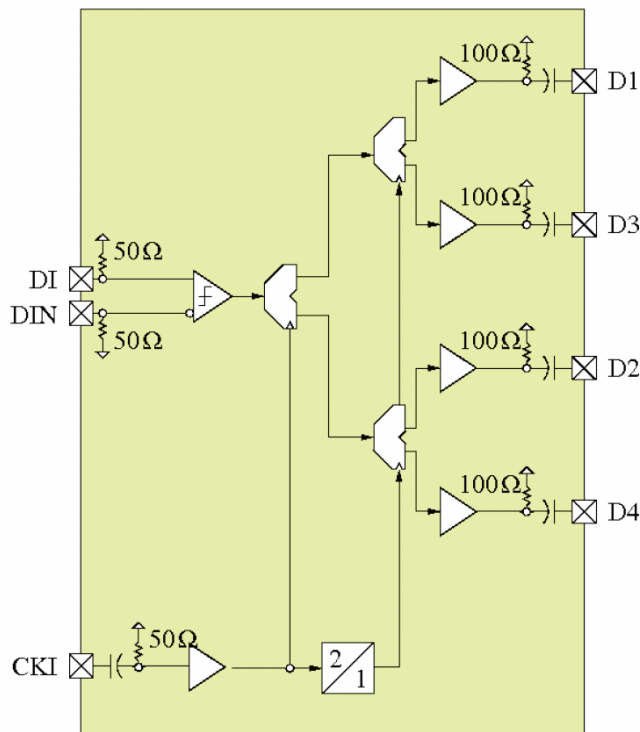

Module Outline

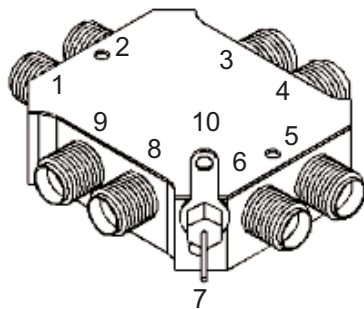

Absolute Maximum Ratings

Parameter	Value	Unit
Supply Voltage (VEE)	-4.0	V
Data Input (DI, DIN)	2.0	Vpp
Clock Input Power (CKI)	+10	dBm
DC voltage (CKI, DI, DIN)	±0.5	V
Operating Temperature	-40 to 85	°C
Storage Temperature	-85 to 150	°C

Pin Description

Name	PIN	DESCRIPTION	NOTE	CONNECTOR
D1	1	Data Channel Output - Bit Position 1	Leading/First serial data bit	2.92 mm (K)
D3	2	Data Channel Output - Bit Position 3	Third Bit	2.92 mm (K)
DI	3	Data Channel Input	Positive Terminal of Differential Input	1.85 mm (V)
DIN	4	Data Channel Input	Negative Terminal of Differential Input	1.85 mm (V)
D4	5	Data Channel Output - Bit Position 4	Trailing/Last Bit	2.92 mm (K)
D2	6	Data Channel Output - Bit Position 2	Second Bit	2.92 mm (K)
VEE	7	Negative Supply Voltage	DC pin, -3.6V @290mA	-
CKI	8	Clock Input	Half of Bit Rate, ie: 20GHz for 40Gb/s Single-ended input	2.92 mm (K)
VCC	10	RF & DC Ground	Chassis/Module Connection	-
NC	9	No Connect	-	-

Packaging Information

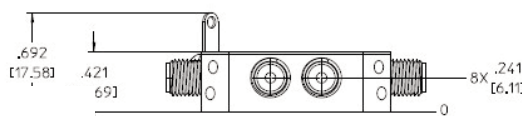
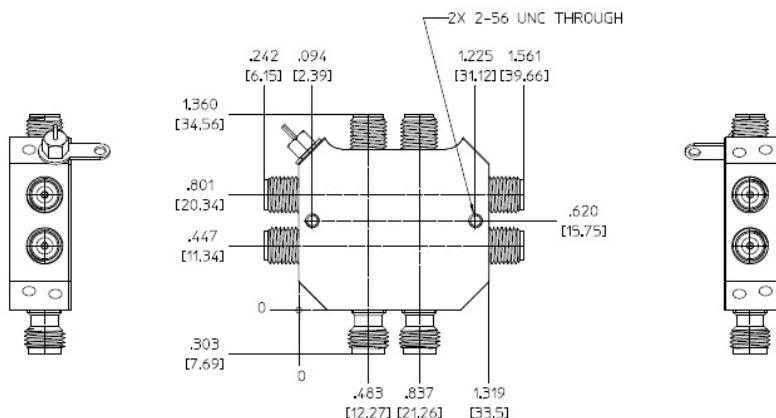
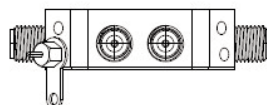

Note: all measurements in inches [mm]