

Clock Recovery Unit (CRU) Module

Features

- 39.8 - 44 Gb/s Data Rates
- High Input Sensitivity
- Low Jitter Output Clocks
10 and 20 GHz
- Low Power Consumption
- Single -3.3V Power Supply

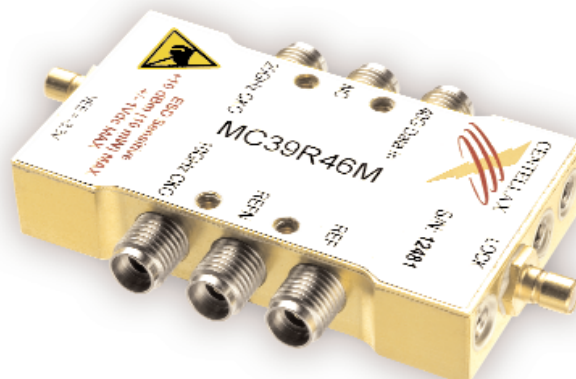

Description

The MC39R46M can be used to extract low jitter clock for SONET and SDH applications operating at transmission speeds of 40 Gb/s. Broadband test systems will benefit from the low power dissipation, precision connectors and excellent signal quality.

Applications

The MC39R46M is a Clock Recovery Unit (CRU) using Silicon Germanium (SiGe) process technology. The module accepts input data rates at 40 Gb/s with an input sensitivity greater than 100mVppk. The data input is AC coupled and terminated with a 50 ohm resistor to minimize reflections. Recovered clocks at 10 and 20 GHz are output via AC coupled outputs with ECL compatible signal levels.

Key Specifications @ 33°C

V_{ee} = -3.3V, I_{ee} = 180mA, Z_o = 50 Ω

Parameter	Description	Minimum	Typical	Maximum
Din (Gb/s)	Input Data Rate	39.8	-	44
Vin (mVppk)	Data Input Level	100	-	400
V20G(mVppk)	20GHz Output Voltage Swing	100	200	-
V10G(mVppk)	10GHz Output Voltage Swing	150	300	-
S11 (dB)	Data Input Return Loss	-	-15	-10
S22 (dB)	20GHz Clock Output Return Loss	-	-10	-7
S33 (dB)	10GHz Clock Output Return Loss	-	-10	-7
S44 (dB)	Reference Clock Return Loss	-10	0	+10

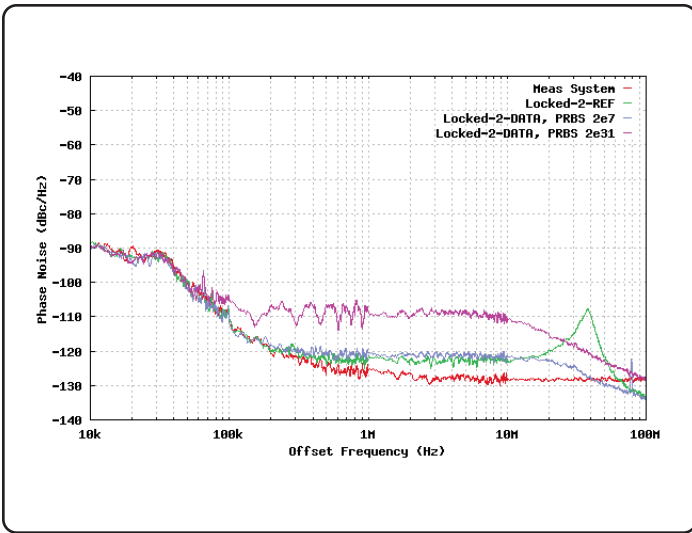

Phase Noise of CKO10G
Carrier Frequency = 19.9 GHz

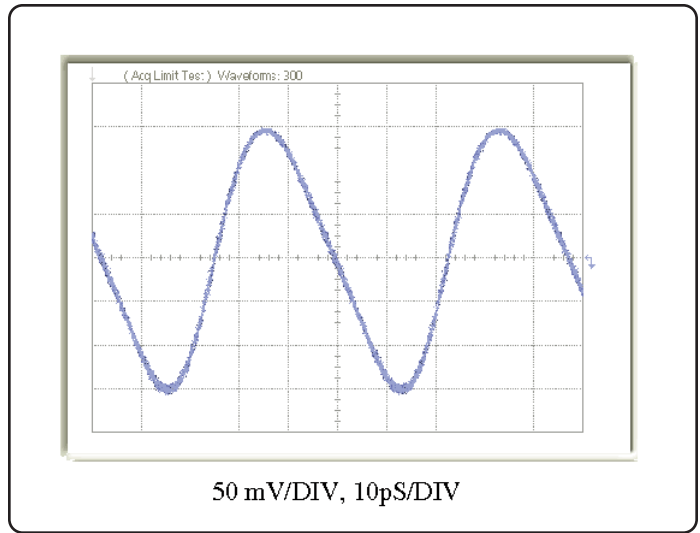

21 GHz Clock Output
Locked to 2.625 GHz Reference

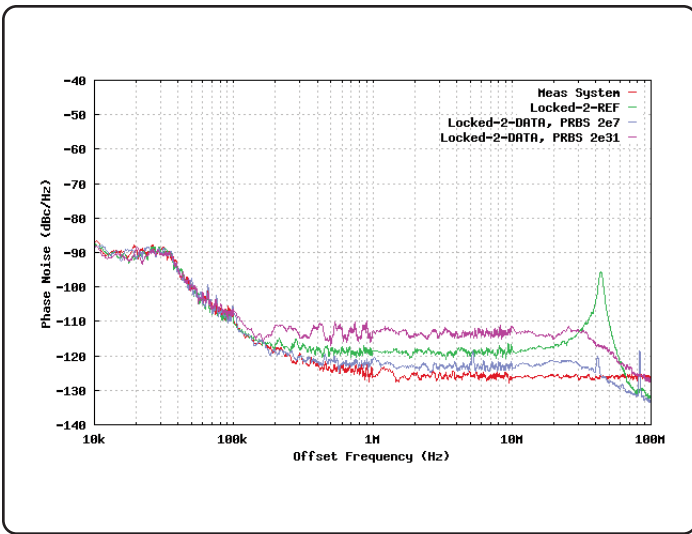

Phase Noise of CKO10G
Carrier Frequency = 21 GHz

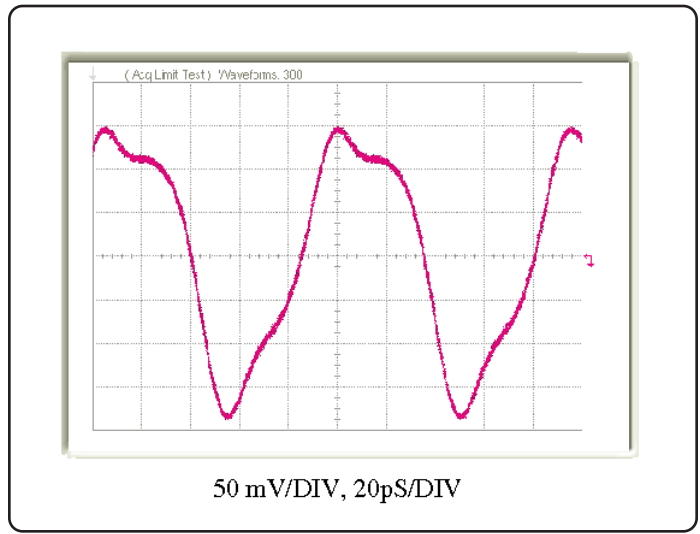

10.5 GHz Clock Output
Locked to 2.625 GHz Reference

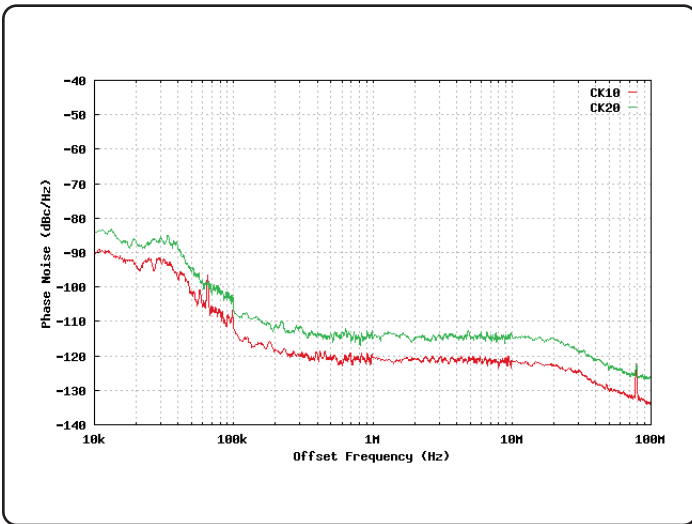

Phase Noise of CKO10G and CKO20G
Locked to 2e7, 39.8 Gb/s data

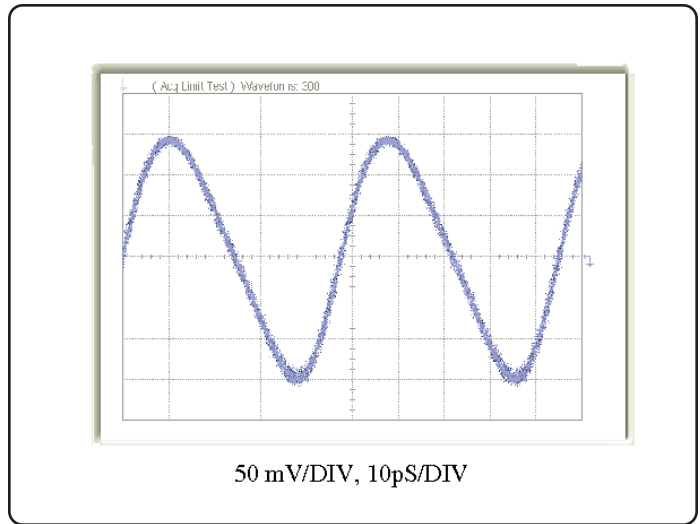

21.0 GHz Clock Output
Locked to 2e31, 42 Gb/s data

Functional Block Diagram

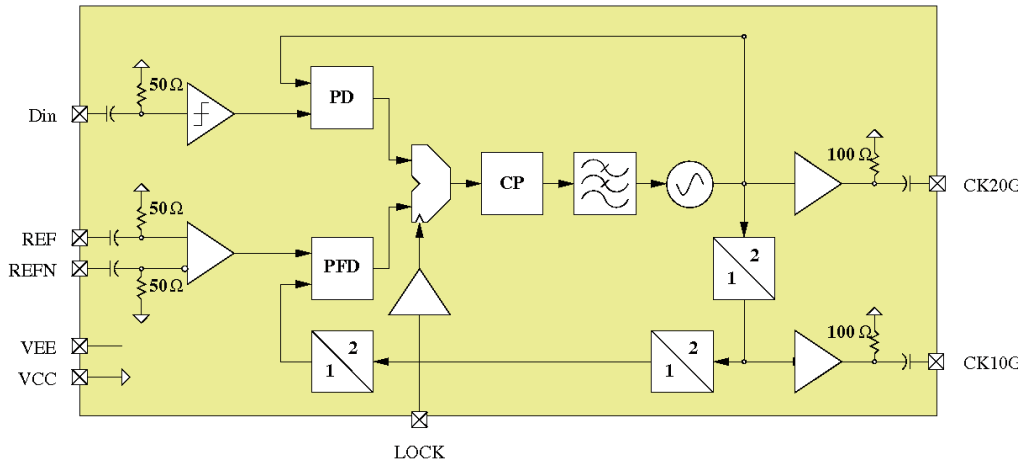

Absolute Maximum Ratings

Parameter	Value	Unit
Supply Voltage (VEE)	-4.0	V
Ref Power (REF, REFN)	+10	dBm
DC Voltage Level (Din,REF,REFN,CK10G,CK20G)	+/-1	V
Operating Temperature	-40 to 80	°C
Storage Temperature	-85 to 150	°C

Module Outline

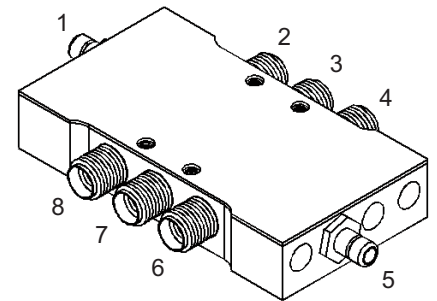

Pin Description

Name	Pin	Description	Note	Connector
Lock	1	Reference Input Selector	Internal PLL Reference Selector Between Input Data and Reference Clock	SMB
REF	2	Reference Clock Input	Positive Differential Input	2.9mm(K)
REFN	3	Reference Clock Input	Negative Differential Input	2.9mm(K)
CK10G	4	10GHz Clock Output*	Single Ended Output	2.9mm(K)
VEE	5	Negative Supply Voltage	Center Pin -3.3V, Shield/Case is ground	SMB
CK20G	6	20GHz Clock Output**	Single Ended Output	2.9mm(K)
NC	7	No Connect		
DIN	8	Data Input	Single Ended Input	2.9mm(K)

*CK20G/2 output

**Half of Data Rate (i.e. 40Gbps Data Rate → 20GHz Clock Speed)

Lock Logic

Parameters	State	Min	Typ	Max	Unit
Low	Data	-	-3.3	-	V
High (default)	Reference Clock	-	0	-	V

Application Note

Clock Recovery

The MC39R46M has two loops with two separate inputs -- one for training the loop to the right frequency, and the other for phase locking the loop to the actual data. Refer to data sheet for block diagram. The part requires a 1/16 rate clock for training the CRU. Once the loop is trained, the input should be switched over to the data input by setting the LOCK pin (pin 1) Low (or -3.3V).

Clock Recovery Procedure

1. Connect both data and reference inputs to the device. The reference clock should be 1/16 of the data rate. For example, if data rate is 40 Gbps, then reference clock is 2.5 GHz (sine or square). Make sure that the LOCK pin (pin 1) is set to High, or 0V, or left open (it defaults to logic state High).
2. Monitor one of the output frequencies to see if the loop has locked to the desired frequency, which should be either 1/2 rate or 1/4 rate, depending on which output you are monitoring. For this example, 1/2 rate is 21.5 GHz, and 1/4 rate is 10.75 GHz.
3. Once the loop is locked (i.e. trained), switch the LOCK pin to Low, or -3.3V, to lock onto the data input.

**The MC39R46M may also be trained using 1/32 to 1/64 of the data rate as the reference clock input; however, the characteristic of the VCO capture range will be reduced.*

Packaging Information

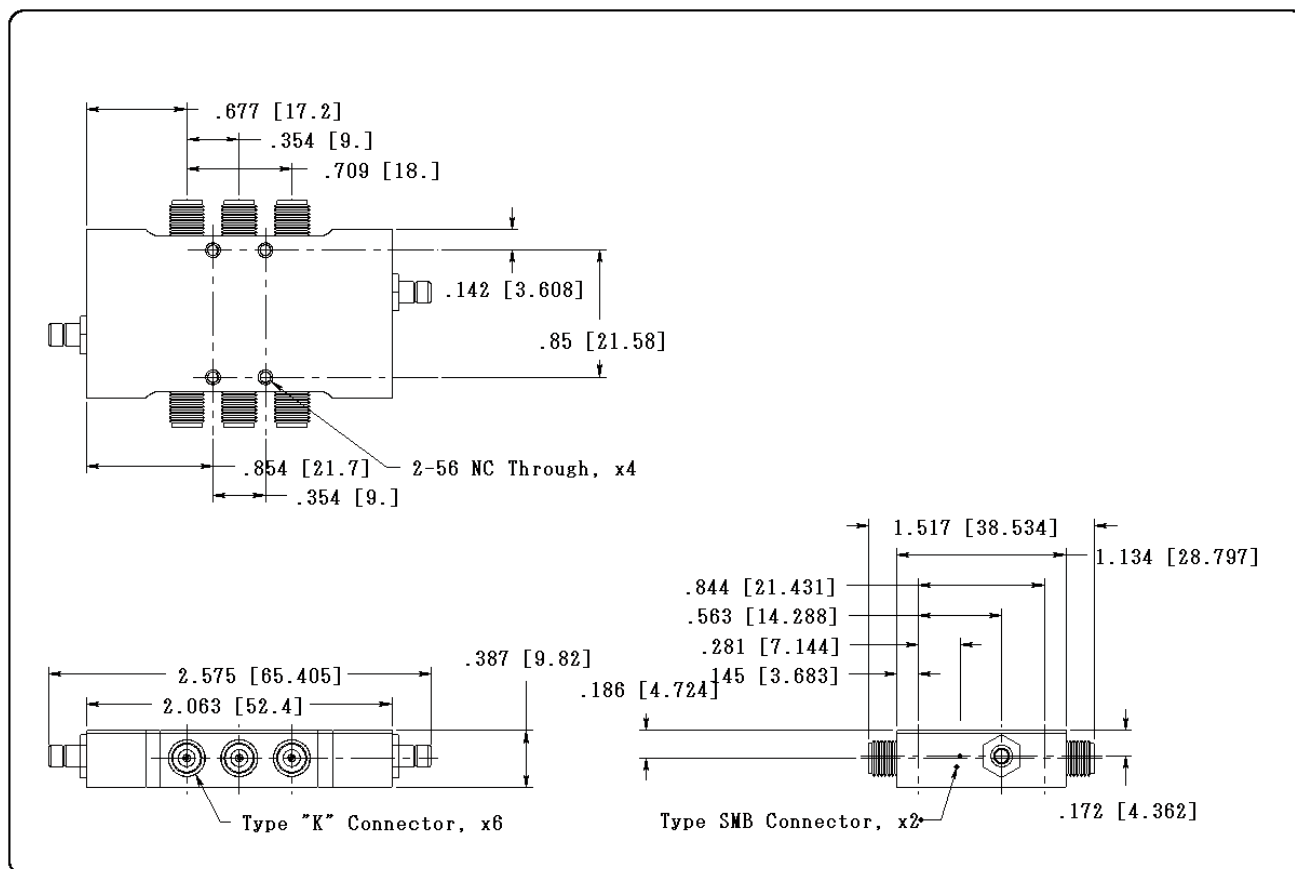

All measurements in inches (mm)